

Americas

147 Central Avenue
Hackensack, NJ 07601
(201) 489-8989
www.cml-it.com

Europe

Robert Bunsen Str. 1
D-67098 Bad Durkheim
+49 (6322) 9567-0
www.cml-it.com

CMDA31 Series Power LED (1 Watt) on Star PCB *CMDA32 Series Power LED (1 Watt) on Square PCB*

- Features

- Super high flux output and high luminance
- Designed for high current operation
- Low thermal resistance
- SMT solder compatible
- Lead (Pb) Free Product – RoHS Compliant

- Applications

- General Illumination
 - Outdoor & Indoor Architectural Lighting
 - Decorative Lighting
 - Portable Lighting / Flash Light (Torch) Lamps
 - Reading Lamps and Task Lighting
 - Traffic Signaling

- Description

These packaged LED's on metal PCB's are designed for high current operation and high flux output applications. The package design features better thermal management characteristics than other LED solutions. Because of these advantages, this product has many applications such as internal & external lighting, automobile lighting, large size LCD backlight, etc.

Americas

147 Central Avenue
 Hackensack, NJ 07601
 (201) 489-8989
www.cml-it.com

Europe

Robert Bunsen Str. 1
 D-67098 Bad Durkheim
 +49 (6322) 9567-0
www.cml-it.com

1. Outline Dimensions

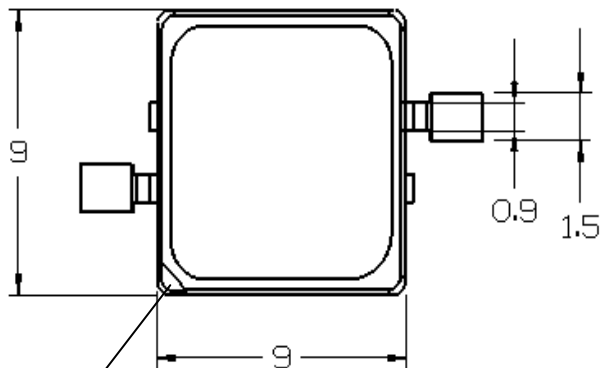

Cathode
 Mark

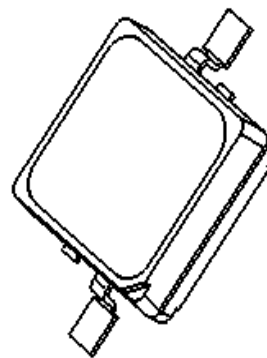
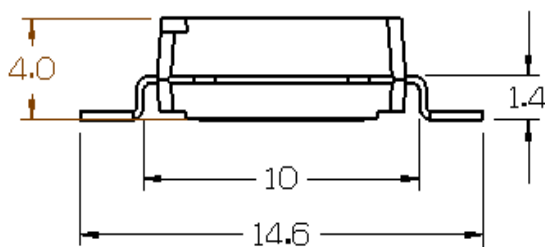

Isometric view
 Scale: None

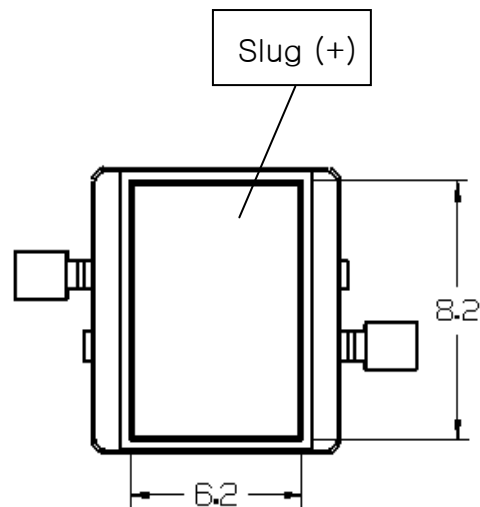

Rear view

- Notes : 1. All dimensions are in millimeters.
 2. Scale : none
 3. This drawing is reference only for engineering

2. Metal Outline Dimensions

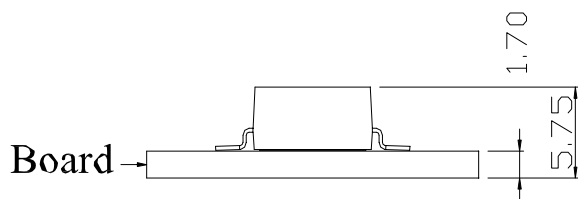
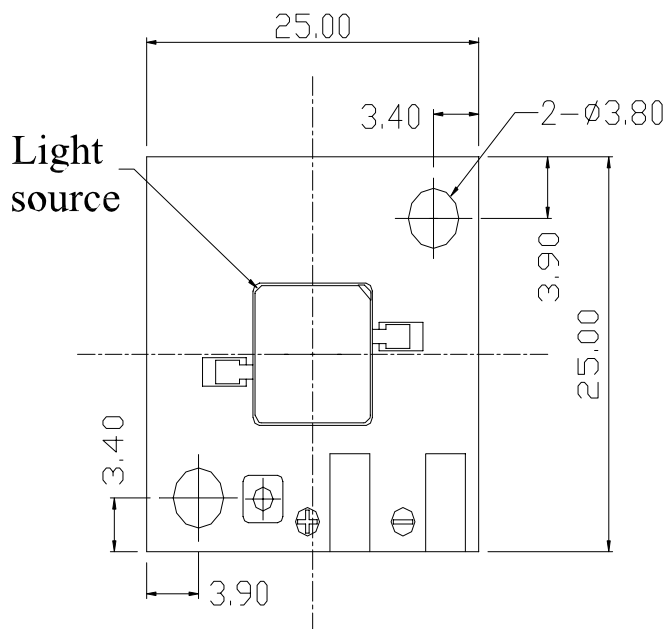

**CMDA32xx15D13L
Square Configuration**

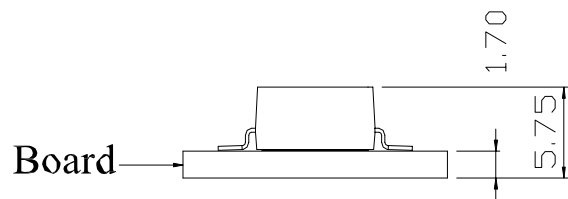
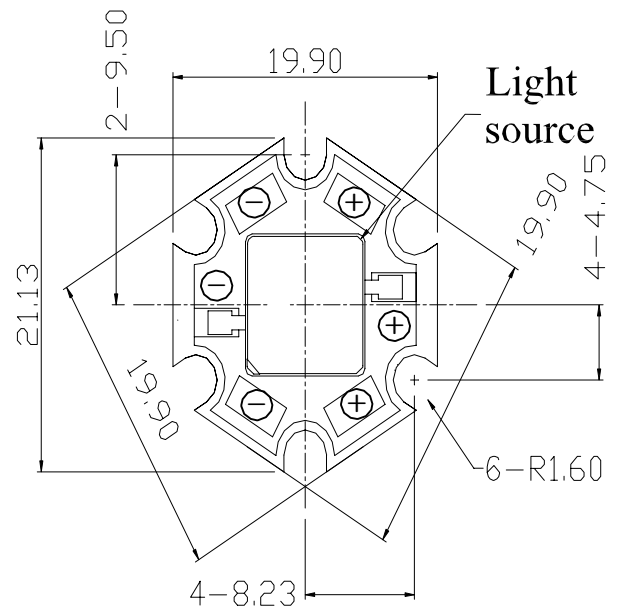

**CMDA31xx15D13L
Star Configuration**

- Note : 1. All dimensions are in millimeters
 2. Scale : none
 3. This drawing is reference only engineering.



Americas
 147 Central Avenue
 Hackensack, NJ 07601
 (201) 489-8989
www.cml-it.com

Europe
 Robert Bunsen Str. 1
 D-67098 Bad Durkheim
 +49 (6322) 9567-0 www.DataSheet4U.com
www.cml-it.com

Americas

147 Central Avenue
 Hackensack, NJ 07601
 (201) 489-8989
www.cml-it.com

Europe

Robert Bunsen Str. 1
 D-67098 Bad Dürkheim
 +49 (6322) 9567-0
www.cml-it.com

3. Electro-Optical Characteristics (at IF=350mA, TA=25°C)

CMDA31xx15D13L Star PCB series

P/N	Description	Luminous Flux Min./Typ. (lm)	Correlated Color Temperature (Kelvin)	CRI	Dominant Wavelength (nm) Min./Typ./Max.	Forward Voltage (volts) Min./Typ./Max.	View Angle (degrees)	Thermal resistance (°C /W)
	Symbol	ΦV [1]	CCT [3]	Ra	λD	V	2Θ 1/2	Rθ [4]
CMDA31CW15D13L	Pure White	32 / 52	6500	76		3.0 / 3.4 / 4.3	110	16
CMDA31WW15D13L	Warm White	24 / 35	3000	76		3.0 / 3.4 / 4.3	110	16
CMDA31CB15D13L	Blue	6 / 11			455 / 460 / 475	3.0 / 3.4 / 4.3	130	16
CMDA31AG15D13L	Green	24 / 48			520 / 527 / 535	3.0 / 3.4 / 4.3	130	16
CMDA31AR15D13L	Red	24 / 30			620 / 625 / 630	2.0 / 2.5 / 3.0	128	19
CMDA31GB15D13L	Cyan	24 / 40			500 / 505 / 510	3.0 / 3.4 / 4.3	130	16
CMDA31DY15D13L	Amber	24 / 38			585 / 590 / 595	2.0 / 2.5 / 3.0	128	19

4. Absolute Maximum Ratings (at TA=25°C)

P/N	Description	Forward Current (A)	Power Dissipation (Watts)	Junction Temperature (°C)	Operating Temperature (°C)	Storage Temperature (°C)
	Symbol	I _F	P _D	T _J	T _{opr}	T _{stg}
CMDA31CW15D13L	Pure White	0.4	1.9	125	-30~+85	-40~+120
CMDA31WW15D13L	Warm White	0.4	1.9	125	-30~+85	-40~+120
CMDA31CB15D13L	Blue	0.4	1.9	125	-30~+85	-40~+120
CMDA31AG15D13L	Green	0.4	1.9	125	-30~+85	-40~+120
CMDA31AR15D13L	Red	0.4	1.2	100	-30~+85	-40~+120
CMDA31GB15D13L	Cyan	0.4	1.9	125	-30~+85	-40~+120
CMDA31DY15D13L	Amber	0.4	1.2	100	-30~+85	-40~+120

***Notes:**

- [1] ΦV is the total luminous flux output as measured with an integrating sphere.
 [2] Zener diode chip included to protect the LED from ESD.
 [3] Rθ is measured with a metal core PCB (25 °C ≤ T_J ≤ 125 °C).
 [4] CML maintains a tolerance of ± 10% on flux and power measurements.
 [5] CCT ± 5% tester tolerance.
 [6] Color Coordinate Measurement allowance is ± 0.005
 [7] A tolerance of ± 0.006V on forward voltage measurements

-----Caution-----

Please do not drive at rated current more than 5 sec. without proper heat sink

Americas

147 Central Avenue
 Hackensack, NJ 07601
 (201) 489-8989
www.cml-it.com

Europe

Robert Bunsen Str. 1
 D-67098 Bad Durkheim
 +49 (6322) 9567-0
www.cml-it.com

5. Electro-Optical Characteristics (at IF=350mA, TA=25°C)**CMDA32xx15D13L Square PCB series**

P/N	Description	Luminous Flux Min./Typ. (lm)	Correlated Color Temperature (Kelvin)	CRI	Dominant Wavelength (nm) Min./Typ./Max.	Forward Voltage (volts) Min./Typ./Max.	View Angle (degrees)	Thermal resistance (°C /W)
	Symbol	ΦV [1]	CCT [3]	Ra	λD	V	2Θ 1/2	Rθ [4]
CMDA32CW15D13L	Pure White	32 / 52	6500	76		3.0 / 3.4 / 4.3	110	16
CMDA32WW15D13L	Warm White	24 / 35	3000	76		3.0 / 3.4 / 4.3	110	16
CMDA32CB15D13L	Blue	6 / 11			455 / 460 / 475	3.0 / 3.4 / 4.3	130	16
CMDA32AG15D13L	Green	24 / 48			520 / 527 / 535	3.0 / 3.4 / 4.3	130	16
CMDA32AR15D13L	Red	24 / 30			620 / 625 / 630	2.0 / 2.5 / 3.0	128	19
CMDA32GB15D13L	Cyan	24 / 40			500 / 505 / 510	3.0 / 3.4 / 4.3	130	16
CMDA32DY15D13L	Amber	24 / 38			585 / 590 / 595	2.0 / 2.5 / 3.0	128	19

6. Absolute Maximum Ratings (at TA=25°C)

P/N	Description	Forward Current (A)	Power Dissipation (Watts)	Junction Temperat ure (°C)	Operating Temperature (°C)	Storage Temperature (°C)
	Symbol	IF	PD	Tj	ToPr	Tstg
CMDA32CW15D13L	Pure White	0.4	1.9	125	-30~+85	-40~+120
CMDA32WW15D13L	Warm White	0.4	1.9	125	-30~+85	-40~+120
CMDA32CB15D13L	Blue	0.4	1.9	125	-30~+85	-40~+120
CMDA32AG15D13L	Green	0.4	1.9	125	-30~+85	-40~+120
CMDA32AR15D13L	Red	0.4	1.2	100	-30~+85	-40~+120
CMDA32GB15D13L	Cyan	0.4	1.9	125	-30~+85	-40~+120
CMDA32DY15D13L	Amber	0.4	1.2	100	-30~+85	-40~+120

***Notes:**

- [1] ΦV is the total luminous flux output as measured with an integrating sphere.
 [2] Zener diode chip included to protect the LED from ESD.
 [3] Rθ is measured with a metal core PCB (25 °C ≤TJ ≤ 125 °C).
 [4] CML maintains a tolerance of ± 10% on flux and power measurements.
 [5] CCT ± 5% tester tolerance.
 [6] Color Coordinate Measurement allowance is ± 0.005
 [7] A tolerance of ± 0.006V on forward voltage measurements

-----Caution-----

Please do not drive at rated current more than 5 sec. without proper heat sink

7. Forward Voltage vs. Forward Current ($T_a=25^\circ\text{C}$)

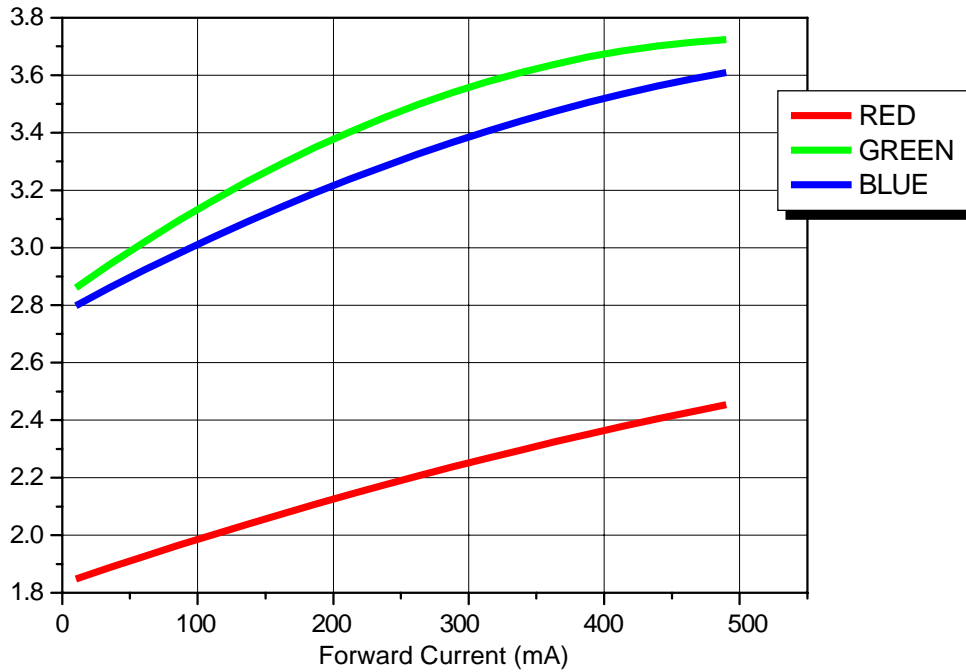

8. Forward Current vs. Normalized Relative Luminous Flux ($T_a=25^\circ\text{C}$)

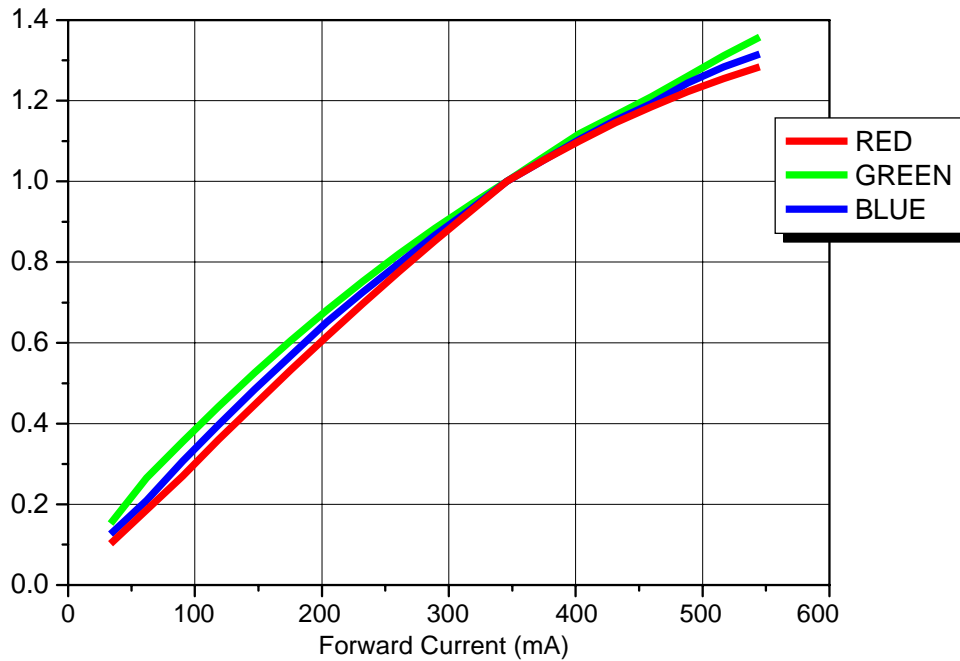

Americas
147 Central Avenue
Hackensack, NJ 07601
(201) 489-8989
www.cml-it.com

Europe
Robert Bunsen Str. 1
D-67098 Bad Dürkheim
+49 (6322) 9567-0
www.cml-it.com

9. White Color spectrum of Typical CCT (Ta=25°C)

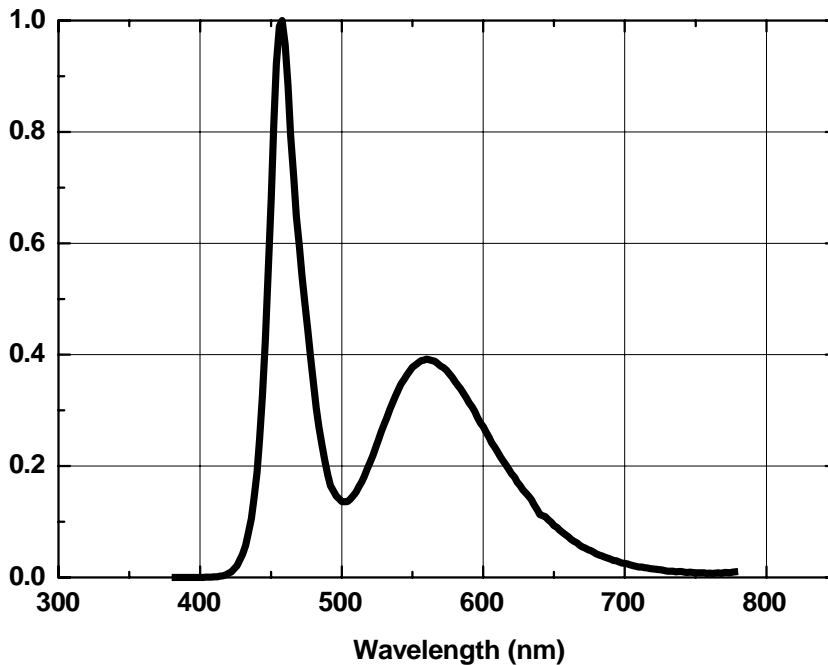

10. Wavelength Curve for Red, Green, Blue

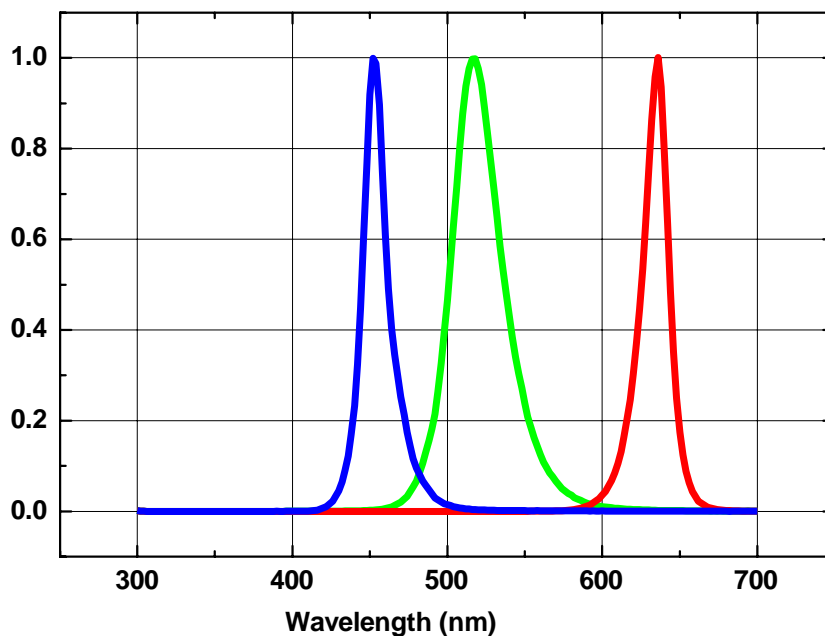

Americas
147 Central Avenue
Hackensack, NJ 07601
(201) 489-8989
www.cml-it.com

Europe
Robert Bunsen Str. 1
D-67098 Bad Dürkheim
+49 (6322) 9567-0
www.cml-it.com

11. Forward Current vs. Wavelength shift ($T_a=25^\circ\text{C}$)

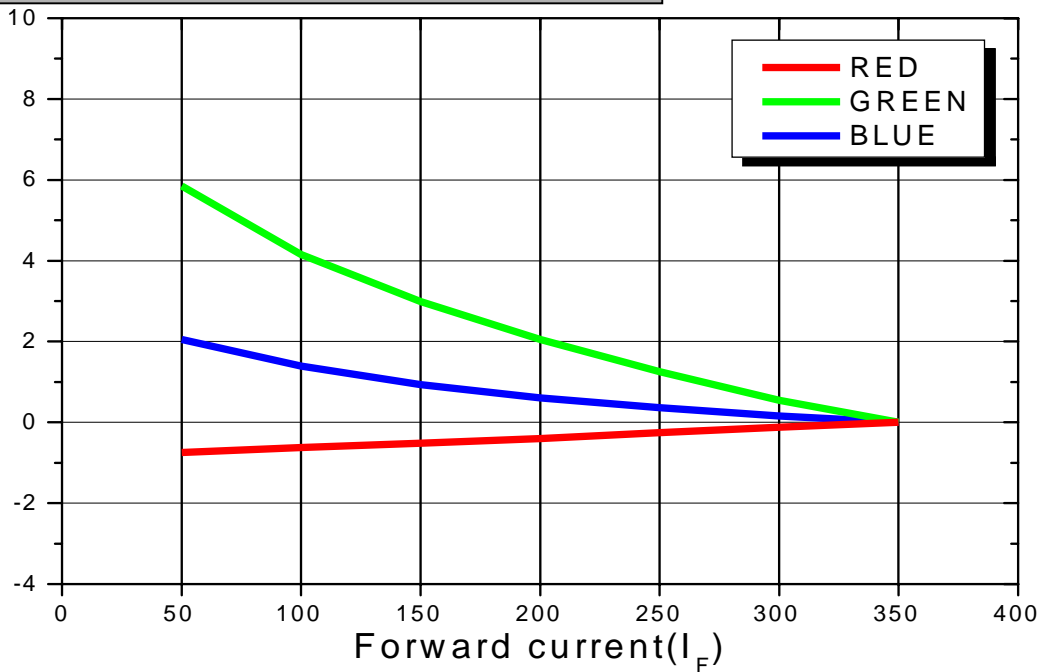

12. Junction Temp vs. Wavelength shift

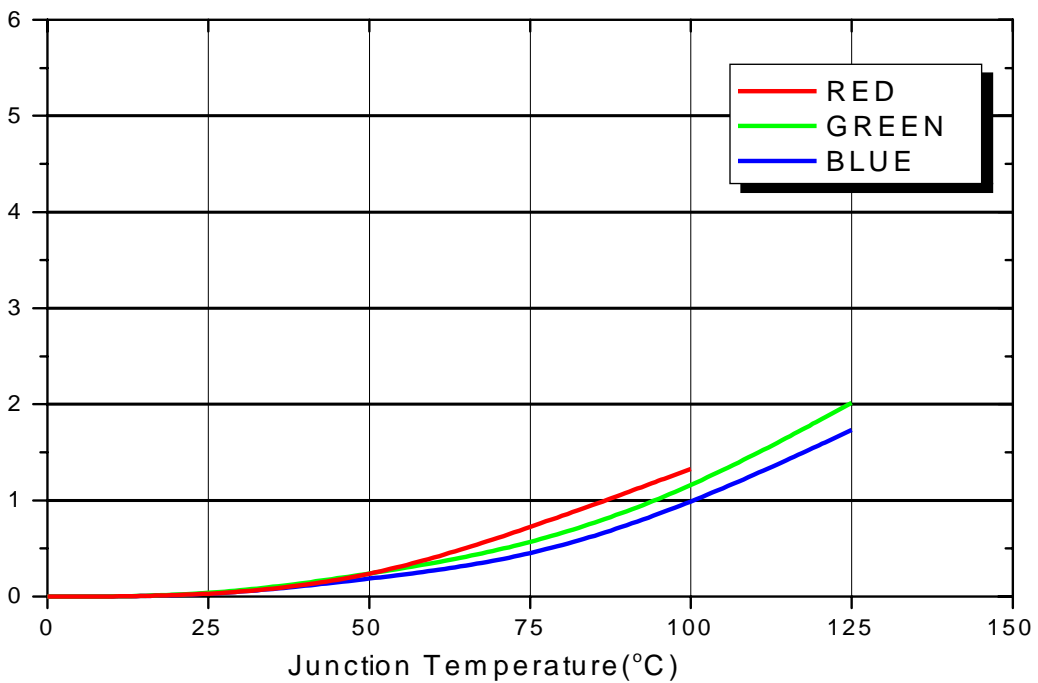

Americas
 147 Central Avenue
 Hackensack, NJ 07601
 (201) 489-8989
www.cml-it.com

Europe
 Robert Bunsen Str. 1
 D-67098 Bad Dürkheim
 +49 (6322) 9567-0
www.cml-it.com

13. Temperature of Junction vs. Relative Light Output for Blue, Green, Red

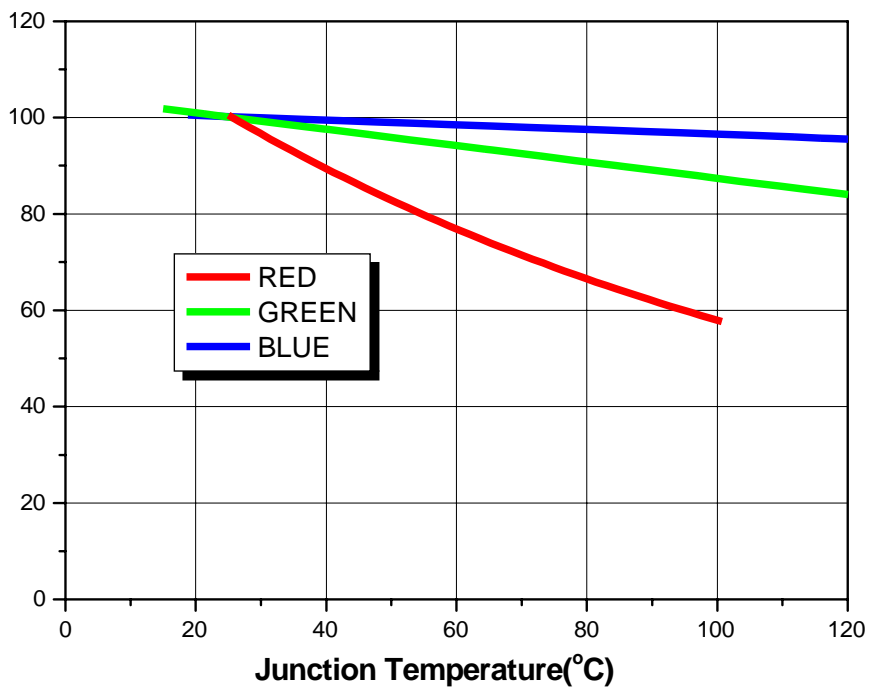

14. Ambient Temperature vs. Allowable Forward Current for 1 chip White, Blue, Green, Cyan

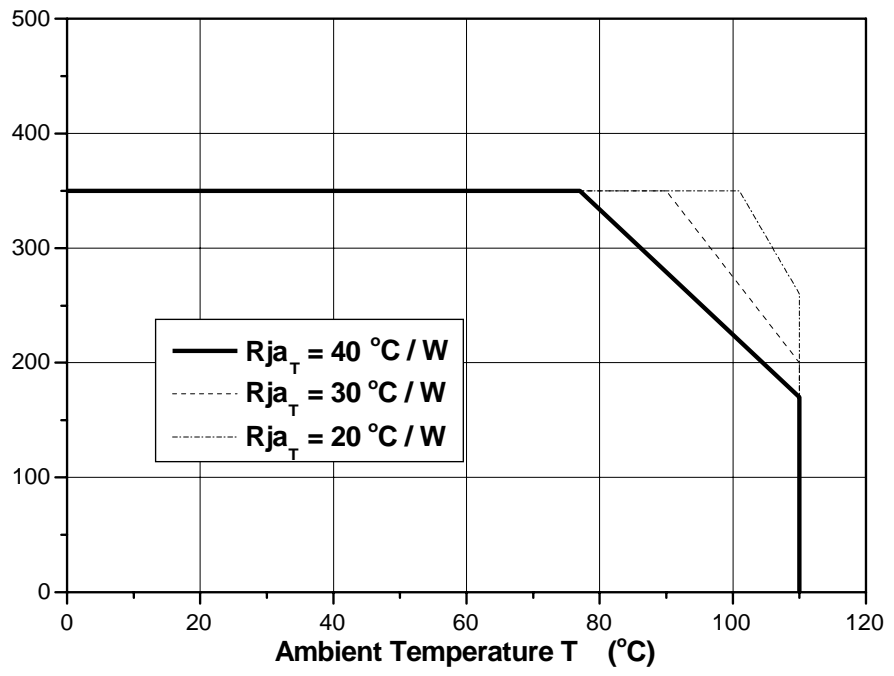

Americas
 147 Central Avenue
 Hackensack, NJ 07601
 (201) 489-8989
www.cml-it.com

Europe
 Robert Bunsen Str. 1
 D-67098 Bad Durkheim
 +49 (6322) 9567-0
www.cml-it.com

15. Ambient Temperature vs. Allowable Forward Current for 1 chip Red, Amber

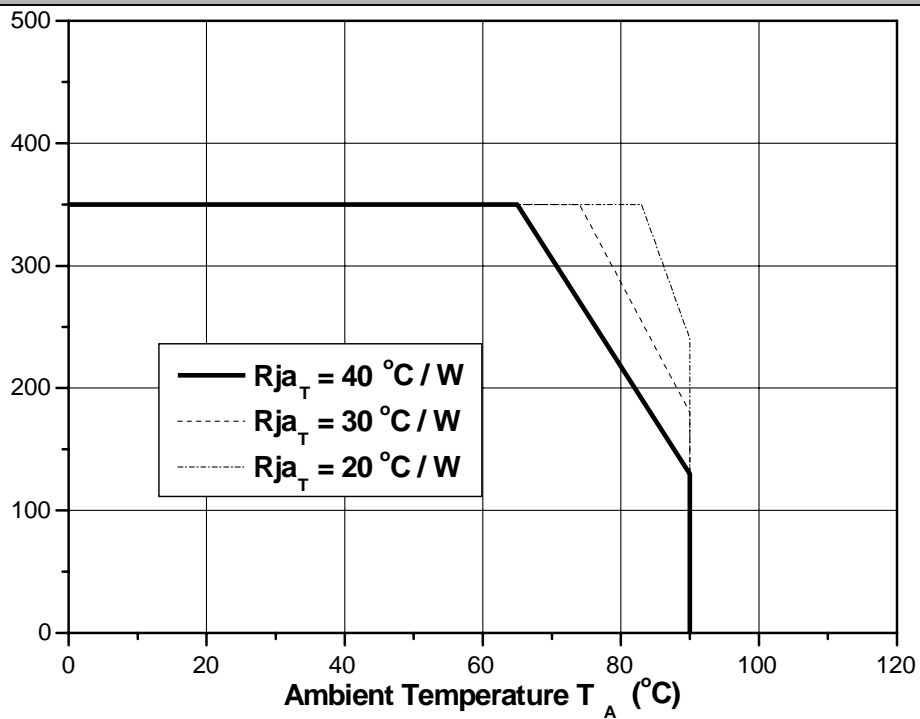

Americas
147 Central Avenue
Hackensack, NJ 07601
(201) 489-8989
www.cml-it.com

Europe
Robert Bunsen Str. 1
D-67098 Bad Durkheim
+49 (6322) 9567-0
www.cml-it.com

www.DataSheet4U.com

16. Reel Packaging Dimensions (Star type)

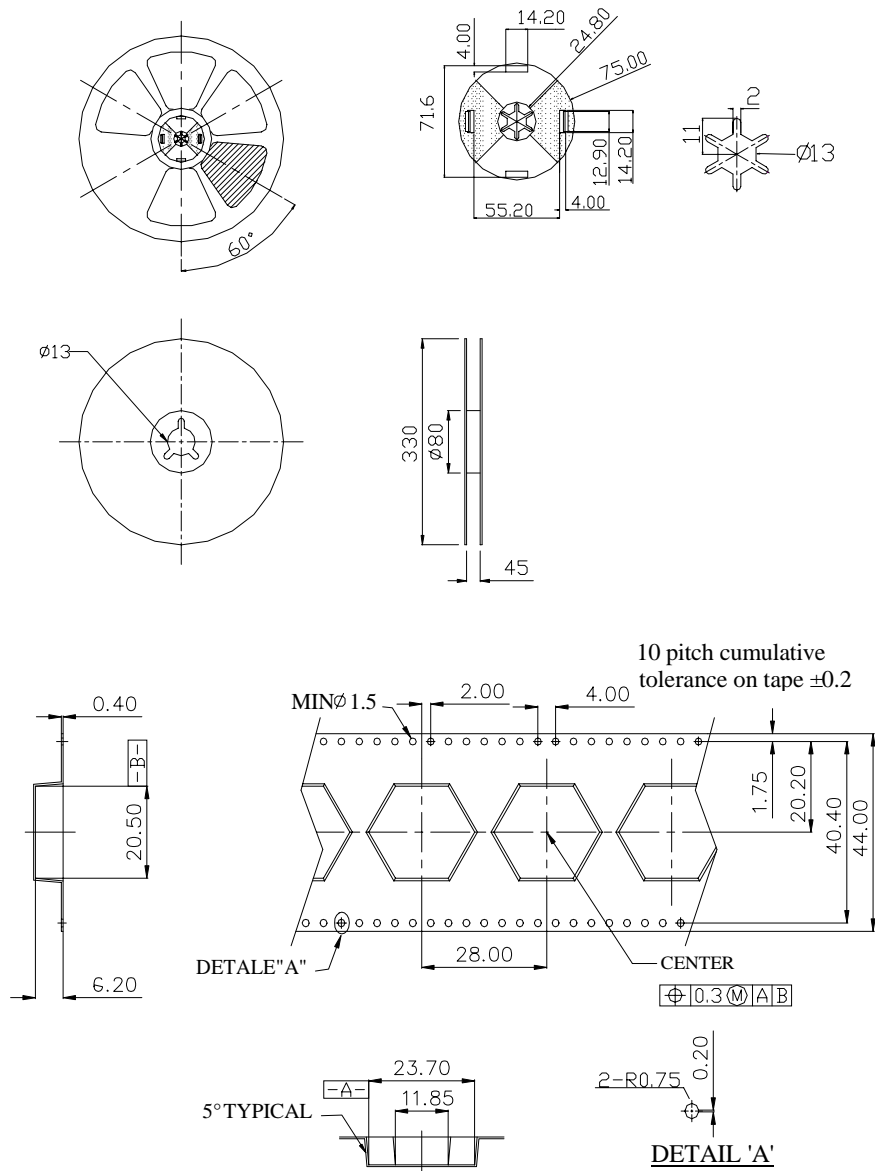

- Note : 1. The number of loaded products in the reel is 350ea
 2. All dimensions are in millimeters
 3. Scale : none
 4. This drawing is reference only engineering



Americas
 147 Central Avenue
 Hackensack, NJ 07601
 (201) 489-8989
www.cml-it.com

Europe
 Robert Bunsen Str. 1
 D-67098 Bad Dürkheim
 +49 (6322) 9567-0
www.cml-it.com

17. Reel Packaging Dimensions (Square type)

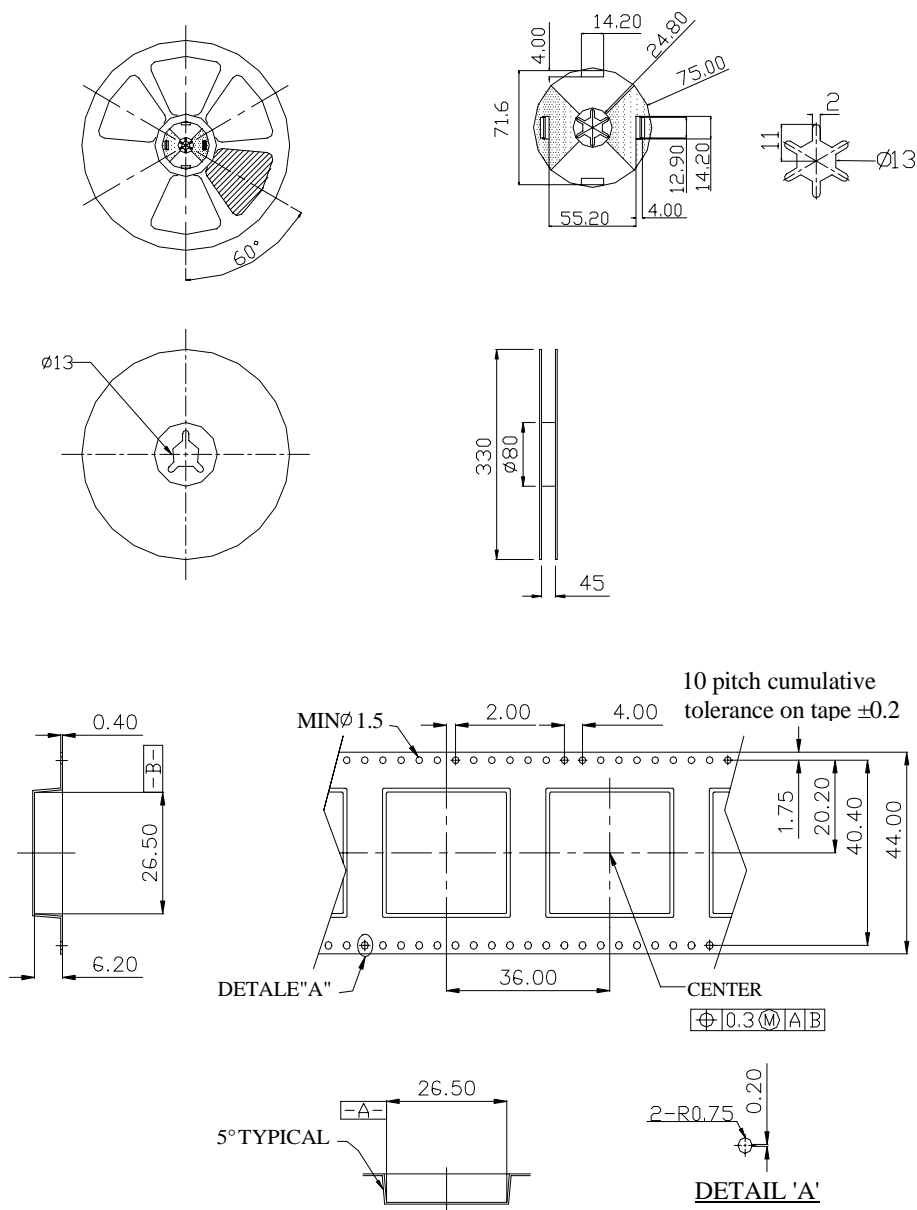

- Note : 1. The number of loaded products in the reel is 200ea
 2. All dimensions are in millimeters
 3. Scale is none
 4. This is drawing is reference only engineering



Americas
 147 Central Avenue
 Hackensack, NJ 07601
 (201) 489-8989
www.cml-it.com

Europe
 Robert Bunsen Str. 1
 D-67098 Bad Dürkheim
 +49 (6322) 9567-0
www.cml-it.com

18. Recommended solder pad

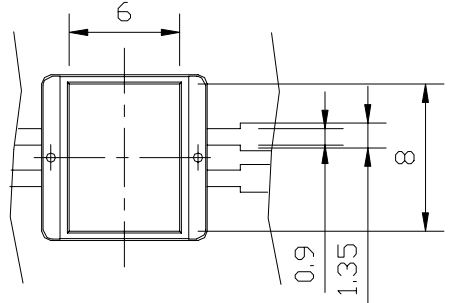
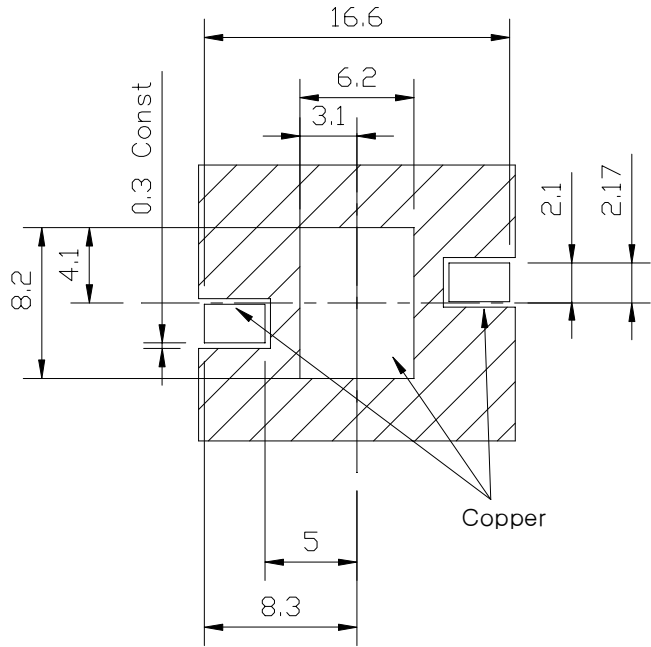
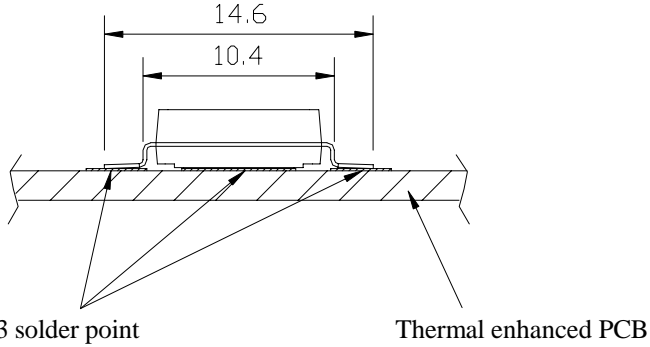

<Rear view>



Americas
147 Central Avenue
Hackensack, NJ 07601
(201) 489-8989
www.cml-it.com

Europe
Robert Bunsen Str. 1
D-67098 Bad Durkheim
+49 (6322) 9567-0 www.DataSheet4U.com
www.cml-it.com

19. Soldering Profile

- (1) Reflow Soldering Conditions / Profile
 Preliminary heating to be at 180°C max. for 2 minutes max.
 Soldering heat to be at 260°C max. for 5 seconds max.

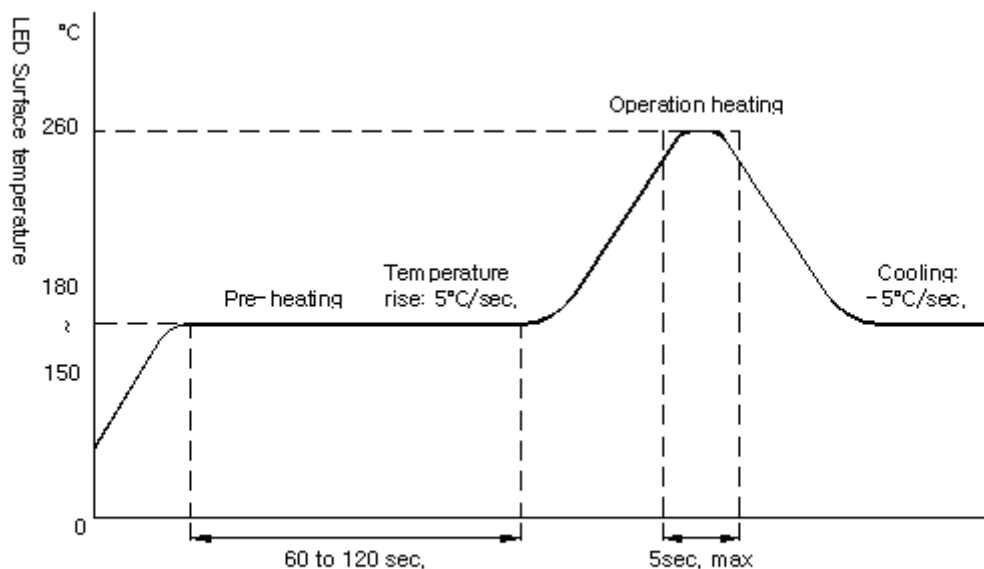

- (2) Hand Soldering conditions
 -Lead : Not more than 3 seconds @MAX280°C, under Soldering iron.

Should soldered products be reused during the soldering process, CML-IT voids all liability on the SMT LED units.



Americas
 147 Central Avenue
 Hackensack, NJ 07601
 (201) 489-8989
www.cml-it.com

Europe
 Robert Bunsen Str. 1
 D-67098 Bad Durkheim
 +49 (6322) 9567-0
www.cml-it.com